

Energy Efficient and Low Cost power Stable Management system in High Speed Single Phase Induction Motor

¹Mr. Ashish S. Jadhav, ²Prof. Lodhi A.K., ³Pallavi R. Suryawanshi.

¹Department of E&TC Engg. Aditya College of Engineering Beed India.

²Head of Department E&TC Engg. Aditya College of Engineering Beed India.

³Department of E&TC Engg. Aditya College of Engineering Beed India.

Abstract- This system saves energy by efficient power management of a room which employs certain controlling mechanisms managed by a microcontroller. In the proposed driver circuit, this problem has been encountered by a microcontroller based automatic adjustable output frequency inverter circuit which is capable of increasing or decreasing output frequency as per desired to any fraction or multiple of supply frequency of 50 Hz. The project aims to build a simple, compact and energy-efficient system for automatic power factor monitoring and energy saving by using Microcontroller. The circuit has been practically implemented and performance on a single phase induction motor. The system has been tested on different loads. The use of 32-bit microcontroller promises extension of the project to a complete power management unit. Apart from lower power consumption, it allows easy extension of functionalities from power data logging, remote monitoring and control, emergency alarm etc.

Keywords- Energy saving, microcontroller, adjustable frequency, single phase induction motor.

I. INTRODUCTION

Induction machines widely have many practical applications in motor drives because of their simplicity of design, reliability, and low manufacturing cost and Energy saving in any system, deals with the minimization of energy wastage. To achieve this, the efficiency of the individual components and processes of the system needs to be improved. Automatic control refers to any controlling mechanism which does not require any human intervention. These two aspects are addressed, to some extent, in this paper. With the continuous rise in the demand and cost of energy, increased power efficiency and quality is very desirable. Power quality can be fairly increased through power factor correction. A compact and efficient system for power factor control and power management can be very useful in industries with high inductive loads. Its use can be extended to within a building or a single machine or appliance. Its use greatly reduces manpower, saves time and space. Moreover, it increases efficiency without human interference and can incorporate built-in intelligence, a compact and efficient power management system. Power Factor is defined as the ratio of the real power delivered to the load to the apparent power. It is a direct measure of the power quality. In an electric power system, a load with a low power factor draws more current than a load with a high power factor for the same amount of useful power transferred. The higher

currents increase the energy lost in the distribution system, and require larger wires and other equipment. Because of the costs of larger equipment and wasted energy, electrical utilities usually charge a higher cost to industrial or commercial customers where there is a low power factor. Poor power factor costs our community in increased electricity charges and unnecessary green house gases. While some countries provide incentives for customers to maintain the required power factor, some impose penalties for power factor dropping beyond a limit. Thus, power factor control is a vital part of efficient power management. Induction motor starting is a well-thought process especially under low power quality supply showing fluctuating voltage and frequency profile. When the voltage is substantially below rated voltage of induction motor or induction motor driven pump, a meticulous observation is needed in order to avoid potential damage while starting. If the voltage is exceedingly low to that of rated voltage, the motor fails to start. As a result, it cannot generate counter electromotive force to compensate. Huge current flows through the winding causing intense heating and vibration. It also can damage the winding insulation. In Bangladesh, Power Quality in terms of voltage stability especially in bucolic region is not satisfactory at all. Being highly dependent on agricultural sector, Pump driven irrigation system exacerbates due to low voltage starting problem. To address this problem with utmost prominence, an effective drive circuit has been proposed in this paper to facilitate a low voltage starting of a single phase induction motor driven pump. The proposed circuit is capable of reducing the output frequency when the supply voltage is substantially low so that constant ratio of voltage and frequency is maintained. Thus during starting at low voltage, output frequency is reduced so that a smooth starting occurs. After starting, there is inertia of the motor which will dominate; so frequency is made to recuperate.

II. OBJECTIVES

A. Energy Saving

The burden on our limited energy resources is to be reduced using efficient energy management, by employing voltage controlling property of triac and motion detection.

B. Automatic Control

This will provide comfort by providing light and temperature control which will reduce user effort.

C. Low Cost Solution

This will be achieved by providing a simple system which will be accessible to low income users.

III. SCHEMATIC DIAGRAM

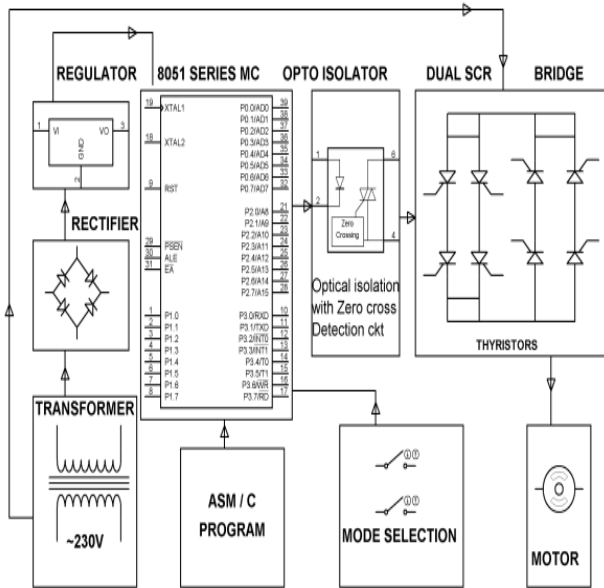

Fig.1 Schematic Diagram using Microcontroller

IV. DESCRIPTION

Single phase 230 V Power supply is given the transformer for step down the voltage from 230v AC to 12V AC. The 12v AC is then fed to the bridge rectifier. The rectifier converts 12V ac to 12VDC. Output of the rectifier is fed to the Voltage regulator 7805 it gives the output of 5V DC. The 5V DC is given to Vcc of the micro controller 8051. The micro controller has been programmed i.e. ASM/C program to give output to optical isolation with zero cross detection circuit. It compares two signals in order to get zero crossing whenever the zero crossing occurs it gives an output. . A microcontroller program is developed to control the firing pulses of gate driving circuit, these firing pulses are controlled by DIACs. The output of the cycloconverter is fed to the induction motor to control the speed at different frequencies.

V. AUTOMATIC FREQUENCY CONTROL ALGORITHM

Automatic frequency control algorithm has been applied to the drive circuit in order to reduce the output frequency at low voltage while starting. But when the supply voltage is at or near normal condition, the output frequency is not affected. To perform automatic frequency changing, two advanced feature of microcontroller 10 bit ADC (analog to digital converter) and 16- bit high precision TIMER 1 has been used. ADC works only on 0 to 5 volt analog signal. So firstly, supply voltage is reduced by step-down transformer and then made unidirectional using half wave rectifier. Then this processed signal is supplied to ADC-0 pin of ATMEGA 8 microcontroller. Pulse generating TIMER block activates when it gets the desired frequency to generate from ADC block internally.

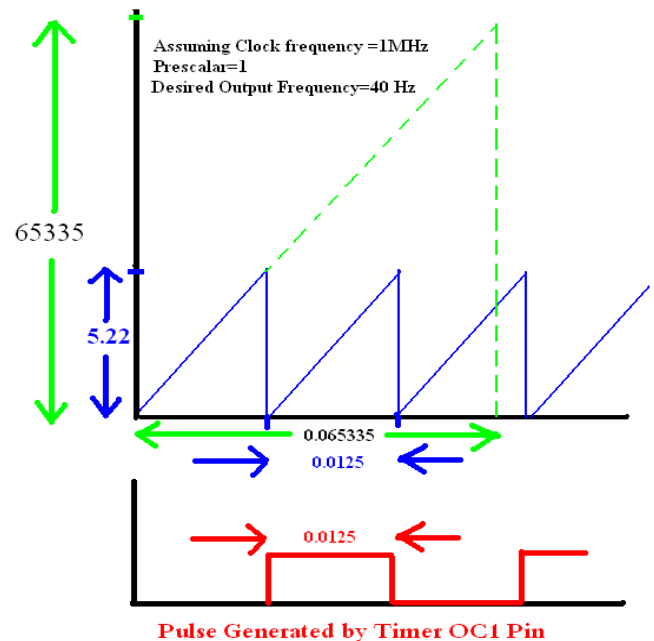

Fig.2. TIMER 1 pulse generation

VI. HARDWARE CIRCUIT

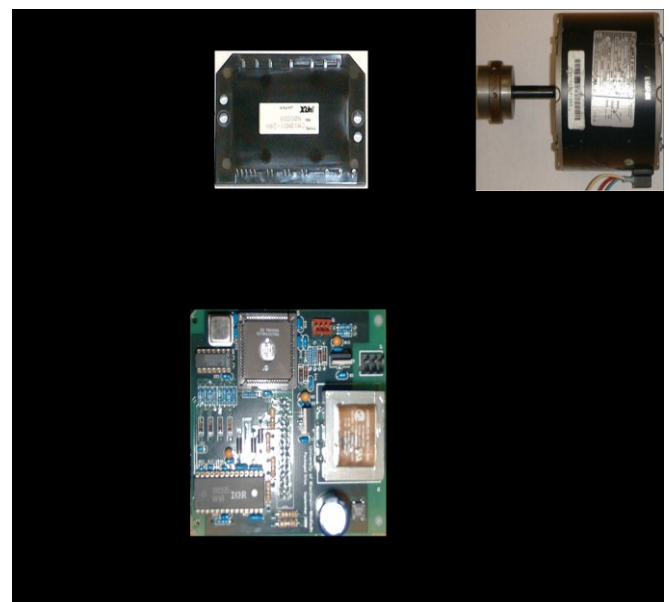

Fig.3. Experiment Setup

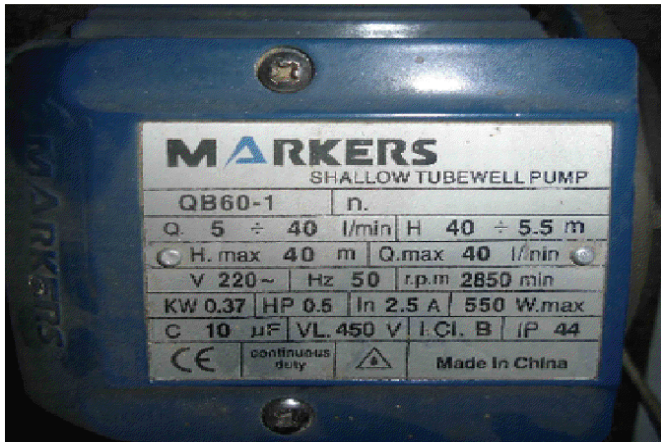

Fig. 4. PUMP specification

VII. PROPOSED SOLUTION

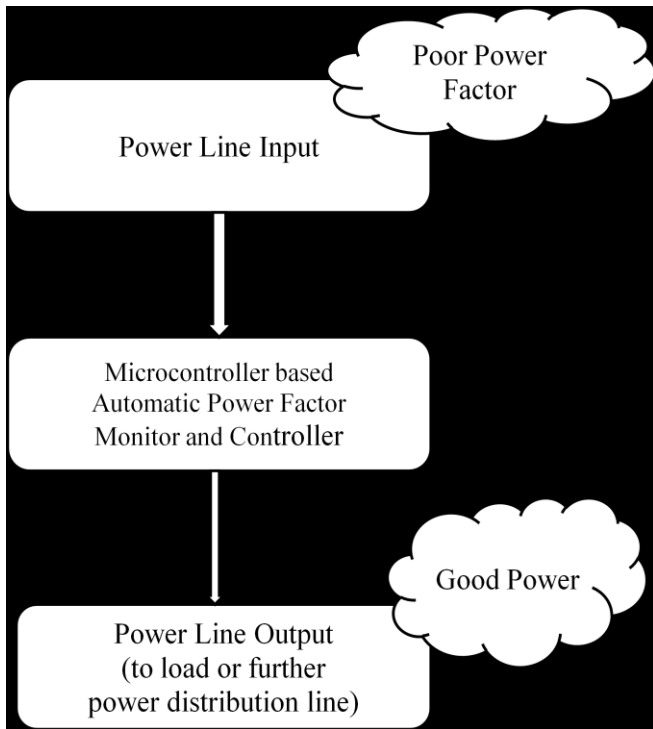

Fig. 5: Top Level Block Diagram

The prototype device ‘cuts’ into a transmission line so that the power factor on the output side is always favorably controlled. The prototype involves a potential transformer selected according to the input power of 220VAC. For different input power line suitable transformers may be selected. The current rating for the current transformer used is 2A. Thus, the load is recommended to be within 440 watts for the prototype. For higher wattage suitable current transformers and relays should be selected. The project aims the development of a simple, energy-efficient, and low-cost power factor controller. It incorporates the inherent

advantages based microcontroller to improve reliability, performance, and affordability based 32-bit microcontrollers are among the most powerful microcontrollers available today and thus its use promises a complete power management unit. Apart from lower power consumption, it allows easy extension of functionalities from power data logging, remote monitoring, emergency alarm etc.

VIII. SPEED CONTROL OF INDUCTION MOTOR

The synchronous speed of the induction motor is given by:

$$N_s = 120f/P \quad (1)$$

Where ‘f’ is frequency and ‘p’ is number of poles.

The running speed of the induction motor is given by the equation:

$$N_r = N_s (1 - s) \quad (2)$$

Where ‘s’ is slip of the induction motor expressed in terms of percentage. The speed control can be performed using open loop algorithms or closed loop algorithms. The most commonly used open loop algorithm is Voltage/ frequency control method. Closed loop algorithms include sensor and sensor less feedback using scalar or vector control. Open loop control of induction motor is used extensively in the industry as it provides the accuracy required at minimal cost. Voltage/ frequency controlled motors fall under the category of Variable Voltage Variable Frequency drives which are fed by an inverter.

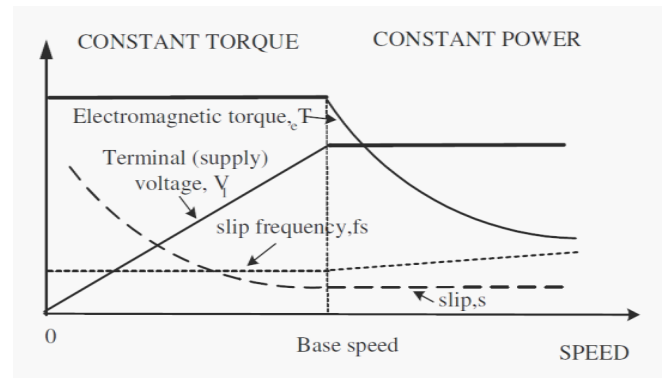

Fig. 6. Modes of operation of VVVF drives under V/ f control method.

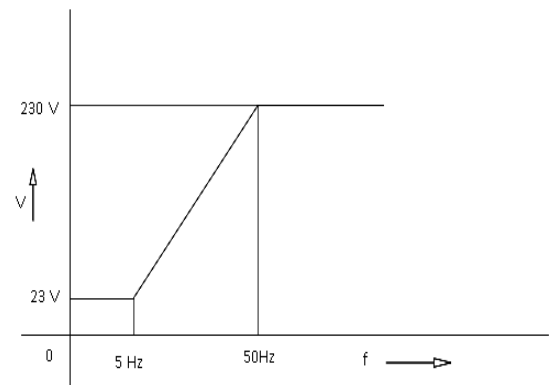

Fig. 7. Variation of Voltage V with respect to frequency f

For maximum torque production, motor flux should be maintained at its rated value.

$$\phi = \phi_m \sin(\omega_1 t) \quad (3)$$

But the back emf is:

$$e_1 = N d\phi / dt = N\omega_1 \phi_m \cos(\omega_1 t) \quad (4)$$

In RMS,

$$e_1 = 4.44 N f_1 \phi_m \quad (5)$$

The modes of operation of a VVVF drive working under Constant V/f control method is given in Figure 6. Figure 7 shows the variation of Voltage V with respect to frequency in a V/f control scheme. At all frequencies above the rated frequency, the voltage is maintained at the rated value. At low frequencies below 5 Hz, the Voltage is maintained at a minimum fixed value. Voltage/ frequency control is based on the following assumptions: The motor impedance increases when the frequency increases and there should be a fixed current as much as possible. So that it is simple to increase the motor speed by increasing the frequency and the related voltage. Variable-frequency drives are widely used in ventilation systems for large buildings, variable-frequency motors on fans save energy by allowing the volume of air moved to match the system demand. They are also used on pumps, conveyor and machine tool drives. Depending on whether the signal voltage is larger or smaller than the carrier waveform, either the positive or negative.

IX. PERFORMANCE APPRAISAL

Main focus of this project work is to correlate input AC voltage versus PUMP speed and water flow rate. As intermediate performance index, input root mean square AC voltage from VARIAC, full wave rectifier output voltage, inverter root mean square output voltage, output root mean square current, PUMP speed and water flow rate has been observed.

IX. CONCLUSION

In this paper, an automated micro-controller based induction motor starting algorithm and circuit configuration has been discussed. The proposed driver circuit has been implemented practically and the experimental result shows conspicuous aggrandizement in terms of successful reduction of threshold starting voltage at chequered supply voltage showing persistent low voltage. In manufacturing and process industries, the variable frequency is required for driving various electrical machineries. The variable frequency generator plays a significant role in driving those electrical machineries. The study mainly focuses on the design the circuit of speed control of single phase Induction motor.

REFERENCES

- [1] "Adjustable Frequency Single Phase Induction Motor Driver for Low Supply Voltage Starting" Shariar Kabir, Md. Jannatul Ferdous, Md. Ali Azam; 978-1-4799-0400-6/13©2013 IEEE
- [2] Methods for the Control of Large Medium-Voltage Motors: Application Considerations and Guidelines", Kay,

J.A., Paes, R.H., Seggewiss, J.G., Ellis, R.G., IEEE Transactions On Industry Applications, Vol. 36, No. 6, November/December 2000.

[3] "Starting High Inertia Loads" McElveen, R.F., Toney, M.K., IEEE Transactions on Industry Applications, Vol. 37, No. 1, January/February 2001.

[4] Li, H., Curiac, R.S., "Designing More Efficient Large Industrial Induction Motors by Utilizing the Advantages of Adjustable-Speed Drives", *Industry Applications, IEEE Transactions on*, on page(s): 1805 - 1809 Volume: 46, Issue: 5, Sept.-Oct. 2010

[5] Larabee, J.; Pellegrino, B.; Flick, B., "Induction motor starting methods and issues," Petroleum and Chemical Industry Conference, 2005. Industry Applications Society 52nd Annual, vol., no. pp. 217- 222, 12-14 Sept. 2005.

[6] M.S. Alam, E. Kabir, M.M. Rahman, and M.A.K. Chowdhury, Power sector reform in Bangladesh: Electricity distribution system, *Energy*, Volume 29, Issue 11, September 2004, Pages

[7] AungZawLatt Ni Ni Win, *Variable Speed Drive of Single Phase Induction Motor Using Frequency Control Method*, International Conference on Education Technology and Computer, 2009. ICETC '09. 7-20 April 2009, pp 30-34.

[8] B. Collis, "An Introduction to Microcontrollers and Software Design," MRGS Technology Electronics, 2003, pp. 40-44.