

Automatic Water Level Indicator & Controller (To control water level of overhead tank)

Ajinkya Kaner¹, Milind Rane²

¹Student, Electronics Department, Vishwakarma Institute of Technology, Pune

²Assistant Professor, Electronics Department, Vishwakarma Institute of Technology, Pune

Abstract- We all use water daily for various purposes but not many of us really care for the unnecessary wastage of water. There is water crisis in Asia, especially for drinking water, which is scaling to considerable peaks. This might very soon attain the nature of global crisis. Therefore, it is of utmost importance to preserve water. Today, in many houses, commercial properties, etc there is unnecessary wastage of water due to overflow in overhead tanks. 'Automatic Water Level Indicator and Controller' can be a solution to it. The operation of water level controller works upon the fact that water conducts electricity due to the presence of minerals within it. Thus water in the tank can be used to close a circuit. As the water level rises, different circuits in the controller send different signals. These signals are used to automatically switch OFF the motor pump so as to avoid the unnecessary wastage of water.

It can be said that, about 95% of the Earth's water is in the oceans which is unfit for human consumption. So, out of the remaining 5%, about 4% is locked in the polar ice caps and the rest 1% constitutes all fresh water found in rivers, streams and lakes which is suitable for our consumption. A study estimated that a person in India consumes on an average of 140 liters per day which would rise by 40% by the year 2025. This definitely signifies that there is a need to preserve the fresh water resources available in nature.

Index Terms- Automatic controller, diode 1N4007, SPDT Relay, transistors BC548, water wastage

I. INTRODUCTION

A water level indicator may be defined as a system by which we can get the information of water level within the reservoir. Each and every time it might not be possible for the operator to keep an eye on the water filling process in the reservoir and immediately switch the motor OFF manually once the reservoir is completely filled. It may happen few times that the operator might be busy with some work and unknowingly forgets about switching the motor OFF manually and due to this kind of negligence [2], there might be unnecessary wastage [5] of water. Keeping this in mind we have designed a system which can avoid these issues by completing the task automatically.

The automatic water level indicator and controller systems are quite useful to reduce the wastage of water from any reservoir, while filling water in such reservoir without

worrying about switching the motor OFF once the reservoir is completely filled so as to avoid wastage of water.

In this project we have used four probes namely A,B,C,D which are adjusted at four different levels in such a way that the three of them namely B,C,D are used to sense the three levels 1, 2 and 3 respectively of water in the tank. The fourth probe namely A is used as common and reference level to the three probes. In this project we have also used three LED indicators namely Red (Level 1), Yellow (Level 2) and Green (Level 3) which are connected to the three transistors.

The four segments of insulated conducting probes (namely A, B, C, D) are immersed within the water tank by placing their naked ends at various abovementioned levels with the help of a rod. The length of the wire segments are adjusted according to the different water levels within the tank to indicate the required three water levels. This is easily visualized by observing the three LED indicators. Once the Level 3 is sensed by probe-D in the water tank, the Green LED blinks indicating the tank is completely filled which in turn automatically switches the motor OFF by the relay [7] switching mechanism so as to avoid wastage of water.

II. WORKING PROCEDURE

The working procedure [6] of this project is: the circuit consists of four sensing probes namely A, B, C, D which are dipped in water at various levels to sense the level of water in the tank. The probe A is connected as common to other three, which should be at the bottom most part of the water tank, also it act as a reference level. The probes B, C, and D are set as Minimum/Slightly filled (Level 1), Half filled (Level 2) and Fully filled (Level 3) respectively.

The circuit is assembled on a general zero PCB. On the PCB, three LED indicators – Red, Green, Yellow are connected to the three BC548 transistors [3] T1, T2 and T3. Both the LEDs and the transistors have been connected with the resistors of required values. Short length single stranded wires are used as sensing probes A, B, C and D. A Single Pole Double Throw (SPDT) relay switch is connected to the transistor T3.

A 1N4007 diode [1] is connected to the relay switch. A motor is connected to the normally closed terminal of the relay switch allowing it to work till the common pole is shifted to normally open terminal. A power supply of 5V is supplied to the circuit and that of 12V is supplied to the relay switch.

When the power is supplied, as soon as the water in the tank touches the probe A and B both, a small current flows from A to B through water and to the base of transistor T1 via a 220Ω resistor. As a result the transistor conducts causing

the Red LED to glow indicating that the water is filled to a minimum required level.

Similarly, when water touches sensing probe C, a small current flows from A to C through water and to the base of transistor T2 via a 220Ω resistor. As a result the transistor T2 conducts causing Yellow LED to glow and indicates that the tank is half-filled and still the pump works and it gives the information about the level of water in the tank.

Finally, when the water in the tank touches sensing probe D, a small current flows from A to D through water and to the base of transistor T3 via a 220Ω resistor. As a result the transistor T3 conducts causing the Green LED to glow and indicates the tank is completely filled and immediately the pole of the relay switch shifts from normally closed to normally open which disconnects the motor from the circuit and stops functioning. This prevents the unnecessary wastage of water once the tank is completely filled.

III. CIRCUIT DESCRIPTION

The circuit for this project can be referred from the Fig. 1 which gives an overview of how the connections of the necessary components are made so as to achieve the automated system to indicate and control water level & avoid its wastage.

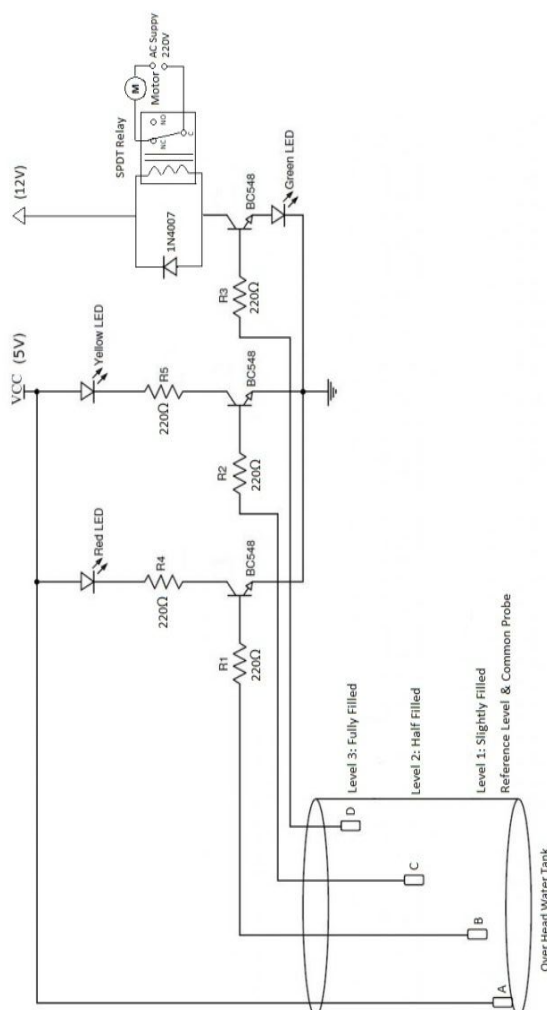

Figure 1: Circuit Diagram

IV. HARDWARE SETUP

The hardware setup including all the required components, equipments and circuits for this project can be referred in the Fig. 2.

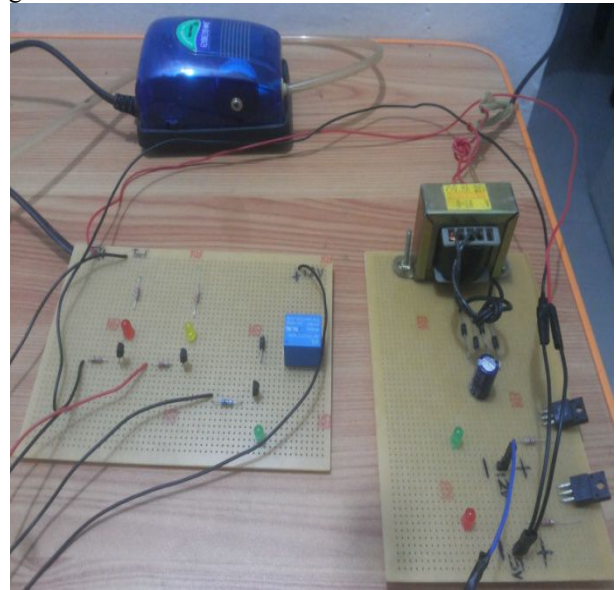

Figure 2: Hardware Kit Setup (PCBs with necessary components, Motor & Power Supply)

The hardware components used for the system includes:

A. Single Pole Double Throw Relay Switch:

The SPDT Relay (10A) [JQC-3FC (T73) DC5V] is a high quality Single Pole Double Throw Relay (SPDT). The Relay consists of a coil, 1 common terminal, 1 normally closed terminal, and one normally open terminal. When the coil of the relay is at rest (not energized), the common terminal and the normally closed terminal have continuity.

When the coil is energized, the common terminal and the normally open terminal have continuity. This relay's coil is rated up to 5V and the contact is rated up to 10A (@120VAC, 24VDC). In this project we have connected the motor to the normally closed terminal due to which it can keep on working until the tank gets completely filled and common terminal shifts to the normally open terminal which in turn disconnects the motor from the circuit.

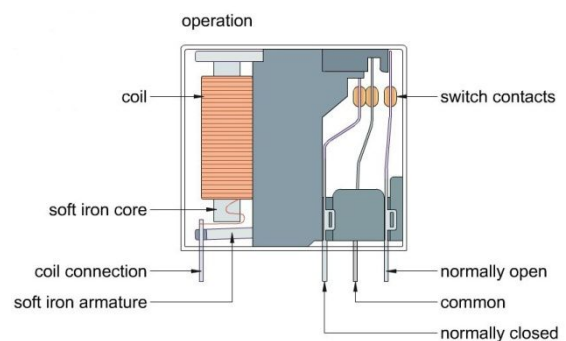

Figure 3: SPDT Internal Structure

B. BC548 Transistors:

BC548 is general purpose silicon, NPN, bipolar junction transistor. It is used for amplification and switching purposes.

The current gain may vary between 110 and 800. In this project this transistors are acting as switches. It will act as closed switch when voltage at base terminal is greater than or equal to 0.7V, else it will act as open switch. It will display the common emitter configuration and is made up of silicon.

C. 1N4007 Diode:

A diode allows electrical current to flow in one direction, from the anode to the cathode. Therefore, the voltage at the anode must be higher than at the cathode for a diode to conduct electrical current. In theory, when the voltage at the cathode is greater than the anode voltage, the diode will not conduct electrical current. Here, once the circuit is ON when power supply is provided, it will initially act as a reverse bias & once the power supply is OFF, it will act as forward bias and help in dissipation of induced EMF in the coil of relay.

D. Light Emitting Diodes (LED):

LEDs are a particular type of diode that converts electrical energy into light. The positive side of the LED is called the Anode and is marked by having a longer Lead or Leg. The other, negative side of the LED is called the Cathode. Current flows from the anode to the cathode and never the opposite direction. We have used three LEDs which indicates the three levels of water in the tank. Once the tank is completely filled the final Green LED blinks and the relay switches the motor OFF automatically.

E. Resistors:

Resistors act to reduce current flow, and, at the same time, act to lower voltage levels within circuits. In electronic circuits, resistors are used to limit current flow, to adjust signal levels, bias active elements, and terminate transmission lines among other uses. We have used 220Ω resistors at base of transistors and at the anode of the LED's for the required functions referring the datasheets.

F. Power Supply:

A dual power supply of 5V & 12V is designed as needed which is shown in Fig. 4. The 5V supply is given to the left part of the circuit in which transistors, LED (YELLOW and RED) indicators and the resistors are connected as per the necessary requirements.

A 12V supply is given to the right side of the circuit in which SPDT relay is used and a transistor with the GREEN LED indicator.

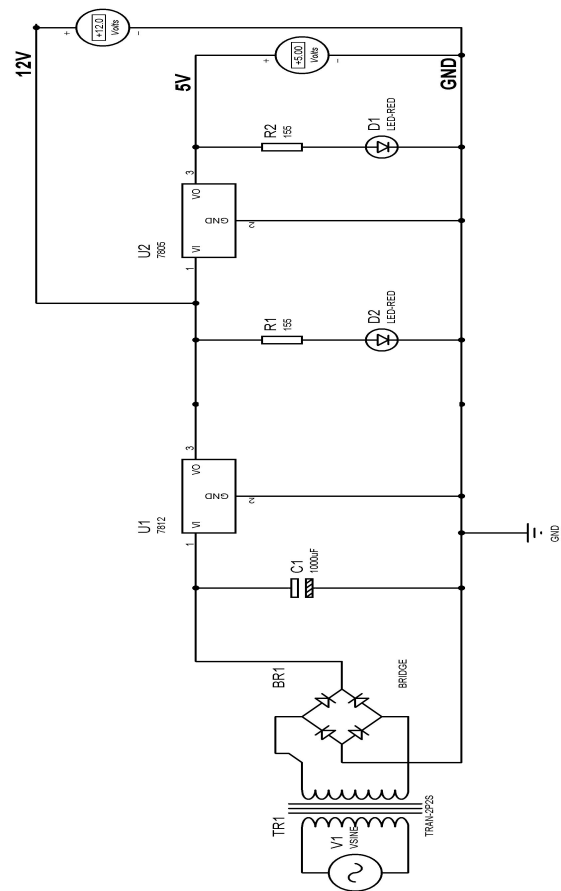

Figure 4: Circuit Diagram of Dual Power Supply of 12V and 5V

V. RESULTS

We can see the results of three LEDs indicating the three Levels 1, 2 and 3 achieved by water in the tank, displayed by Red, Yellow and Green LEDs respectively. The output of these results can be seen in the figures- 5,6, 7. The result shown in figure 7 indicates that the tank is completely filled by achieving the Level 3 in water tank which in turn switches the motor OFF immediately due to the relay mechanism.

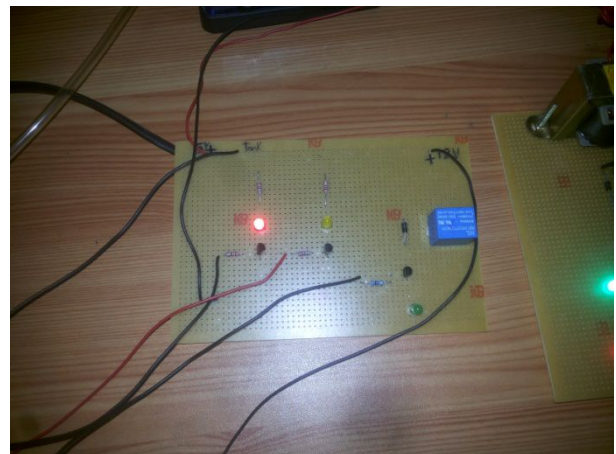

Figure 5: Red LED- Level 1 reached Indicating the tank is Slightly filled

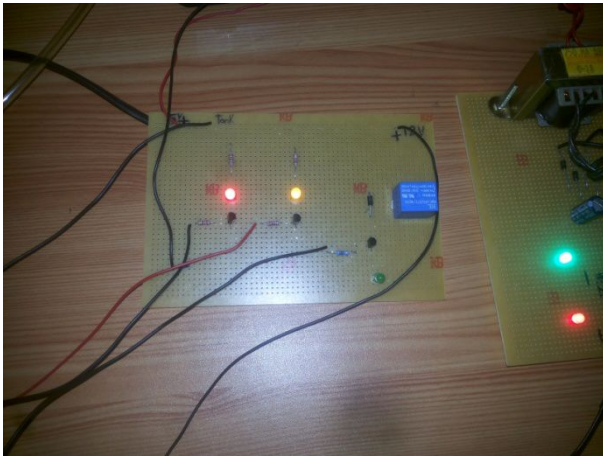

Figure 6: Yellow LED- Level 2 reached Indicating the tank is Half filled

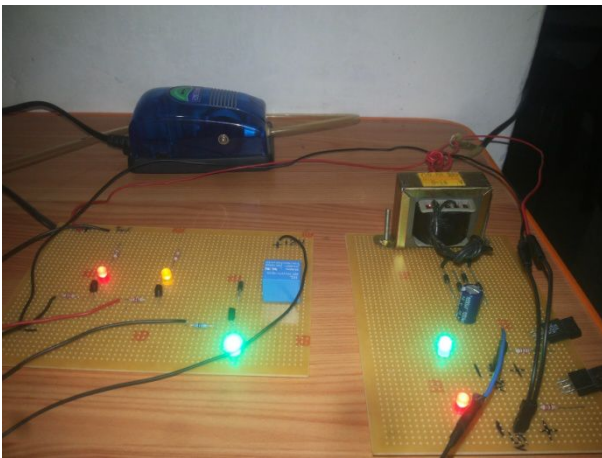

Figure 7: Green LED- Level 3 reached Indicating the tank is Completely filled

VI. APPLICATIONS

There are various applications of this project. Automatic Water Level Indicator & Controller can be used in different sectors such as Hotels, Factories, Homes Apartments, Commercial Complexes, Industries, Agricultural Purposes etc. It can be used to indicate fuel or oil levels in tanks or vehicles.

VII. FUTURE SCOPE

Main intension of this project is to establish a flexible, economical and easy configurable system which can solve water losing problems. In the near future as home automation web based water level monitoring and controlling system can be designed, through which the system can be controlled from any place via internet through mobile phone. A GSM module can be integrated so as to receive the current status via SMS in registered cell-phones.

It can be modified and put to great use like taking preventive steps when some natural calamities like floods, drainage overflows etc are detected and for avoiding highly in-toxic liquid overflows in chemical plants etc. This could save precious lives of number of living beings. Also the assets purchased from hard earned money could be refrained from getting damaged with the prior information from such automated indicators and controllers.

VIII. CONCLUSION

This paper was intended to design a simple and low cost automatic water level indicator and controller. This is not only for water tank but also can be used for various liquids & oil level in industries and chemical labs too. To design this system, we used transistor as a platform connected to relay along with local materials for low cost.

We tried to design a system in such a way that its components will be available easily and when connected together, will be able to prevent the wastage of water. The whole system operates automatically. So it does not need any expert person to operate it. It is not at all very expensive. This design has much more scope for future research and development. Though it is a project, we hope some modification in this project will lead to a reasonable diversity of usage.

REFERENCES

- [1] Diodes Incorporated, 'Datasheet: Rectifier, 1N4001 - 1N4007, 0.1A', Document number: DS28002, Rev. 9 – 3, September 2014
- [2] European Business and Technology Centre, 'Report: Water & waste water in India'.
- [3] Fairchild Semiconductor Corporation, 'Datasheet: BC546 / 547 / 548 / 549 / 550 NPN Epitaxial Silicon Transistor', Rev. A2, August 2002
- [4] 'IEEE', Published Papers, Journals & their Format. Website: https://www.ieee.org/publications_standards/publications/periodicals/journals_magazines.html
- [5] Narayan Hegde, 'Water scarcity and security in India', BAIF at the Indian Science Congress 2012
- [6] 'Working principle of automatic water level controller ', Website: <http://waterlevelcontrols.com>
- [7] Yueqing Hengwei Electronics Co. Ltd, 'Datasheet: PCB Relay - JQC-3F(T73)'